

GMF35HDA**GM**

Front suspension package
Ensemble pour suspension avant
Ensemble para suspensión de delantero

INSTALLATION INSTRUCTIONS

- Raise vehicle allowing the axle to hang freely.
- Remove U-bolt pad from leaf springs & remove rubber bump stop from pad.
- Assemble Aeon rubber spring and bracket as shown in the adjacent diagram.
- Mount Timbren assembly to U-bolt pad and replace pad.
- Replace right stabilizer bar by following OEM specifications.
- Lower vehicle.

NOTES:

To remove bump stop on right side, disconnect front stabilizer bar.

INSTRUCTIONS DE MONTAGE

- Soulever le véhicule de sorte que l'essieu soit dégagé.
- Retirer le coussin du boulon en U des ressorts à lames et retirer la butée de suspension en caoutchouc du coussin.
- Assembler le ressort en caoutchouc Aeon et le support comme il est indiqué dans le schéma adjacent.
- Monter l'assemblage Timbren au \ coussin du boulon en U et remplacer le coussin.
- Remplacer la barre stabilisatrice de droite selon les spécifications du fabricant d'équipement.
- Redescendre le véhicule.

REMARQUES:

Couper la barre stabilisatrice d'en avant pour retirer la butée de suspension du côté droit.

INSTRUCCIONES DE INSTALACIÓN

- Levante el vehículo dejando que los ejes cuelguen libremente.
- Retire el cojín amortiguador del perno "U" de los resortes de ballestas y retire el tope de suspensión de caucho del amortiguador.
- Ensamble el resorte de caucho Aeon y la abrazadera como se muestra en el diagrama adyacente.
- Monte la unidad Timbren al cojín amortiguador del perno "U" y vuelva a colocar el cojín amortiguador.
- Vuelva a colocar la barra estabilizadora derecha según las especificaciones del fabricante original del equipos.
- Baje el vehículo.

NOTAS:

Para retirar el tope de suspensión en el lado derecho, desconecte la barra estabilizadora delantera.

Ref. = Reference = No. de référence = Núm. de referencia
Part = Part #. = No. de pièce = Núm. de pieza
Qty. = Quantity = Quantité = Cantidad

| Ref | Part | Qty |
|-----|--------------|-----|
| 1 | A0103B-65Q00 | 2 |
| 2 | F11064-150 | 2 |
| 3 | K42033-020 | 2 |
| 4 | K10069-003 | 2 |
| 5 | F31003-150 | 2 |

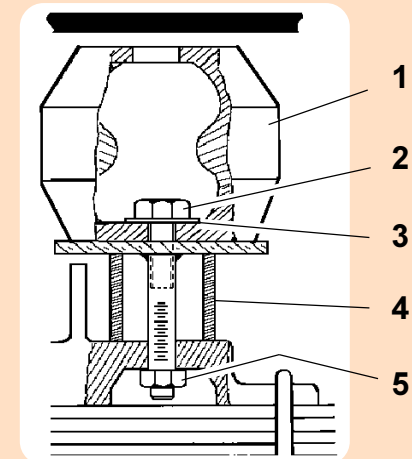

Do not exceed vehicle manufacturer's recommended axle weight rating. Check for AEON[®] interference with vehicle components - Under load AEON[®] will "expand" in diameter.

Ne pas dépasser le poids nominal sur l'essieu recommandé par le fabricant du véhicule. Vérifier que le ressort AEON[®] n'a pas d'incidence sur d'autres pièces du véhicule - Le ressort AEON[®] augmentera son diamètre avec la charge.

No exceda la carga nominal en el eje recomendada por el fabricante del vehículo. Compruebe que no haya interferencia entre el resorte AEON[®] y los otros componentes del vehículo. Bajo carga, el resorte AEON[®] se ampliará en diámetro.

GMF35HDA





Ride Quality Control

TIMBREN SES

Suspension Enhancement Systems

Clearance Instructions

Typical Light Duty & Medium Duty Installation

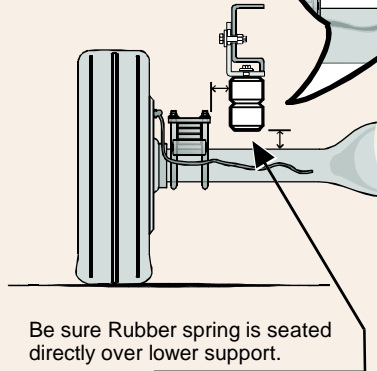
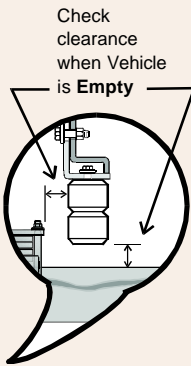

Typical Heavy Duty Installation



For Light Duty Pickups & Vans

Rear SES kits should have approximately 1" gap between rubber spring and axle for 1/2 and 3/4 tons, and for one ton the gap should be about 1/2" when the vehicle is completely unloaded. A cap or fifth wheel plate will reduce or eliminate this gap.

Front SES kits are usually in contact with the front suspension at all times.

For Medium Duty & Heavy Duty Trucks, Trailers, Motor Homes, and more

Medium & Heavy Duty vehicles often have pre-load as outlined in the instruction sheet. (For specific Medium Duty applications with a constant load on the suspension like Rvs, Utility Vans or Cube Vans, the Timbren SES kits are pre-loaded.)

Check clearances when vehicle is empty...

Consider Your Needs..!

Knowing the use of the vehicle will help you to select the right SES kit. For example a one ton truck can be configured as a pick-up, service vehicle or tow truck. Standard capacity or severe service applications are available for many applications.

Knowing that the suspension has been modified or is old and sagging should indicate the need to adjust the ride height to obtain the correct clearance.

This can be done by altering the SES kit (changing rubber spring or bracket) or re-arching the leaf springs to renew the optimum OEM ride height.

Limited Lifetime Warranty

TIMBREN SES kits are warranted against defects in material and workmanship, under normal use and service, for the life of the vehicle on which the kit was originally installed. The warranty is not transferable and proof of purchase is required. The warranty is limited to the replacement of the failed part. TIMBREN will not be responsible for any labour or freight charges involved in the replacement of any product. TIMBREN shall be entitled to make its own inspection to determine the validity of the warranty claim. TIMBREN shall not be liable nor warrant the product in the event of alteration, misuse, overload, negligence or damage caused by others.

If ride is unsatisfactory in any way, please call:

TIMBREN INDUSTRIES INC.

1-800-263-3113

www.timbren.com
email: sales@timbren.com