

GMFC15

GM

Front suspension package Ensemble pour suspension avant Ensemble para suspensión de delantero

INSTALLATION INSTRUCTIONS

- Raise vehicle allowing the axle to hang freely.
- Remove existing bump stop.
- Install T-bolt, flat washer & nut (items 4, 5 & 6) first. (see Diagram)
- Assemble Aeon rubber spring and bracket as shown in the adjacent diagram.
- Lower vehicle.

NOTES:

Turn wheels full lock both directions to ensure there is no interference with Timbren assembly.

INSTRUCTIONS DE MONTAGE

- Soulever le véhicule de sorte que l'essieu soit dégagé.
- Retirer la butée de suspension existante.
- Installer le boulon de type T, la rondelle plate et l'écrou (articles 4, 5 et 6) en premier lieu (voir le schéma).
- Assembler le ressort en caoutchouc Aeon et le support comme il est indiqué dans le schéma adjacent.
- Redescendre le véhicule.

REMARQUES:

S'assurer qu'il n'y a aucune interférence avec l'assemblage Timbren en tournant les roues complètement dans les deux directions.

INSTRUCCIONES DE INSTALACIÓN

- Levante el vehículo dejando que los ejes cuelguen libremente.
- Retire el tope de suspensión existente.
- Instale el perno "T", la arandela plana y la tuerca (ítems 4, 5 y 6) primero. (vea Diagrama)
- Ensamble el resorte de caucho Aeon y la abrazadera como se muestra en el diagrama adyacente.
- Baje el vehículo.

NOTAS:

Gire las ruedas hasta el tope en ambas direcciones para asegurarse de que no hay interferencia con la unidad Timbren.

Ref. = Reference = No. de référence = Núm. de referencia
Part = Part #. = No. de pièce = Núm. de pieza
Qty. = Quantity = Quantité = Cantidad

Ref	Part	Qty
1	A00170-55P20	2
2	K10170-003	2
3	F31003-250	4
4	F40031-020	2
5	F16069-620	2

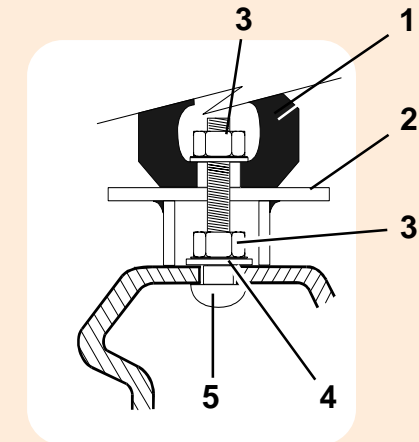
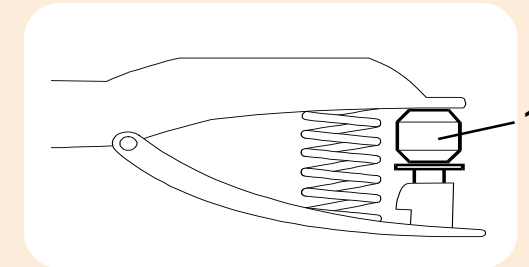

Do not exceed vehicle manufacturer's recommended axle weight rating. Check for AEON® interference with vehicle components - Under load AEON® will "expand" in diameter.

Ne pas dépasser le poids nominal sur l'essieu recommandé par le fabricant du véhicule. Vérifier que le ressort AEON® n'a pas d'incidence sur d'autres pièces du véhicule - Le ressort AEON® augmentera son diamètre avec la charge.

No exceda la carga nominal en el eje recomendada por el fabricante del vehículo. Compruebe que no haya interferencia entre el resorte AEON® y los otros componentes del vehículo. Bajo carga, el resorte AEON® se ampliará en diámetro.

GMFC15





Ride Quality Control

TIMBREN SES

Suspension Enhancement Systems

Clearance Instructions

Typical Light Duty & Medium Duty Installation

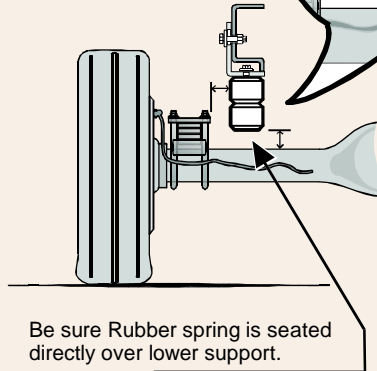
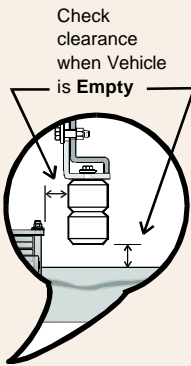

Be sure Rubber spring is seated directly over lower support.

Typical Heavy Duty Installation

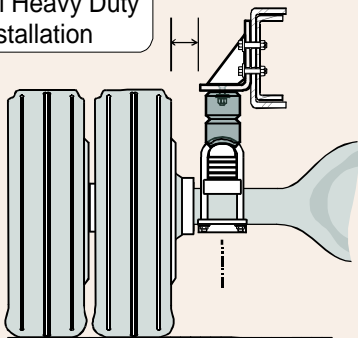

For Light Duty Pickups & Vans

Rear SES kits should have approximately 1" gap between rubber spring and axle for 1/2 and 3/4 tons, and for one ton the gap should be about 1/2" when the vehicle is completely unloaded. A cap or fifth wheel plate will reduce or eliminate this gap.

Front SES kits are usually in contact with the front suspension at all times.

For Medium Duty & Heavy Duty Trucks, Trailers, Motor Homes, and more

Medium & Heavy Duty vehicles often have pre-load as outlined in the instruction sheet. (For specific Medium Duty applications with a constant load on the suspension like Rvs, Utility Vans or Cube Vans, the Timbren SES kits are pre-loaded.)

Check clearances when vehicle is empty...

Consider Your Needs..!

Knowing the use of the vehicle will help you to select the right SES kit. For example a one ton truck can be configured as a pick-up, service vehicle or tow truck. Standard capacity or severe service applications are available for many applications.

Knowing that the suspension has been modified or is old and sagging should indicate the need to adjust the ride height to obtain the correct clearance.

This can be done by altering the SES kit (changing rubber spring or bracket) or re-arching the leaf springs to renew the optimum OEM ride height.

Limited Lifetime Warranty

TIMBREN SES kits are warranted against defects in material and workmanship, under normal use and service, for the life of the vehicle on which the kit was originally installed. The warranty is not transferable and proof of purchase is required. The warranty is limited to the replacement of the failed part. TIMBREN will not be responsible for any labour or freight charges involved in the replacement of any product. TIMBREN shall be entitled to make its own inspection to determine the validity of the warranty claim. TIMBREN shall not be liable nor warrant the product in the event of alteration, misuse, overload, negligence or damage caused by others.

If ride is unsatisfactory in any way, please call:

TIMBREN INDUSTRIES INC.

1-800-263-3113

www.timbren.com
email: sales@timbren.com