

**JRL4****JEEP**

Rear suspension package  
Ensemble pour suspension arrière  
Ensemble para suspensión de trasero

**INSTALLATION INSTRUCTIONS**

- Raise vehicle allowing the axle to hang freely.
- Remove rear coil springs.
- Remove existing bump stop by prying out of bump stop cup
- Position Aeon spring assembly into bump stop cup. Push and twist simultaneously. ( See diagrams A & B.) Ensure the assembly is fully seated in cup.
- Re-install coil springs as per manufacturers instructions.
- Lower vehicle.

**SAFETY CAUTIONS**

Professional installation required.

**INSTRUCTIONS DE MONTAGE**

- Soulever le véhicule de sorte que l'essieu soit dégagé.
- Retirer les ressorts hélicoïdaux arrière.
- Retirer la butée de suspension existante en insérant un levier dans l'échancrure de la butée de suspension.
- Placer le bloc de ressorts Aeon dans l'échancrure de la butée de suspension. Pousser et tourner simultanément. ( Voir les schémas A et B) Veiller à ce que l'assemblage soit entièrement placé dans l'échancrure.
- Remettre en place les ressorts hélicoïdaux selon les instructions fournies par le fabricant.
- Redescendre le véhicule.

**MESURES DE SÉCURITÉ**

Faire appel à un professionnel pour l'installation.

**INSTRUCCIONES DE INSTALACIÓN**

- Levante el vehículo dejando que los ejes cuelguen libremente.
- Retire los resortes helicoidales traseros.
- Retire el tope de suspensión existente haciendo palanca en la copa del tope de retención
- Coloque en posición la unidad de resorte Aeon en la copa del tope de retención. Empuje y tuerza simultáneamente. ( Vea Diagramas A y B.) Asegúrese de que la unidad está totalmente encajada en la copa.
- Reinstale resortes helicoidales según las instrucciones de los fabricantes.
- Baje el vehículo.

**PRECAUCIONES DE SEGURIDAD**

Se requiere instalación profesional.

Do not exceed vehicle manufacturer's recommended axle weight rating. Check for AEON<sup>®</sup> interference with vehicle components - Under load AEON<sup>®</sup> will "expand" in diameter.

Ne pas dépasser le poids nominal sur l'essieu recommandé par le fabricant du véhicule. Vérifier que le ressort AEON<sup>®</sup> n'a pas d'incidence sur d'autres pièces du véhicule - Le ressort AEON<sup>®</sup> augmentera son diamètre avec la charge.

No exceda la carga nominal en el eje recomendada por el fabricante del vehículo. Compruebe que no haya interferencia entre el resorte AEON<sup>®</sup> y los otros componentes del vehículo. Bajo carga, el resorte AEON<sup>®</sup> se ampliará en diámetro.

Ref. = Reference = No. de référence = Núm. de referencia  
Part = Part #. = No. de pièce = Núm. de pieza  
Qty. = Quantity = Quantité = Cantidad

Ref	Part	Qty
1	A25728-90K00	2
2	A00530-55P20	2
3	F11061-150	2

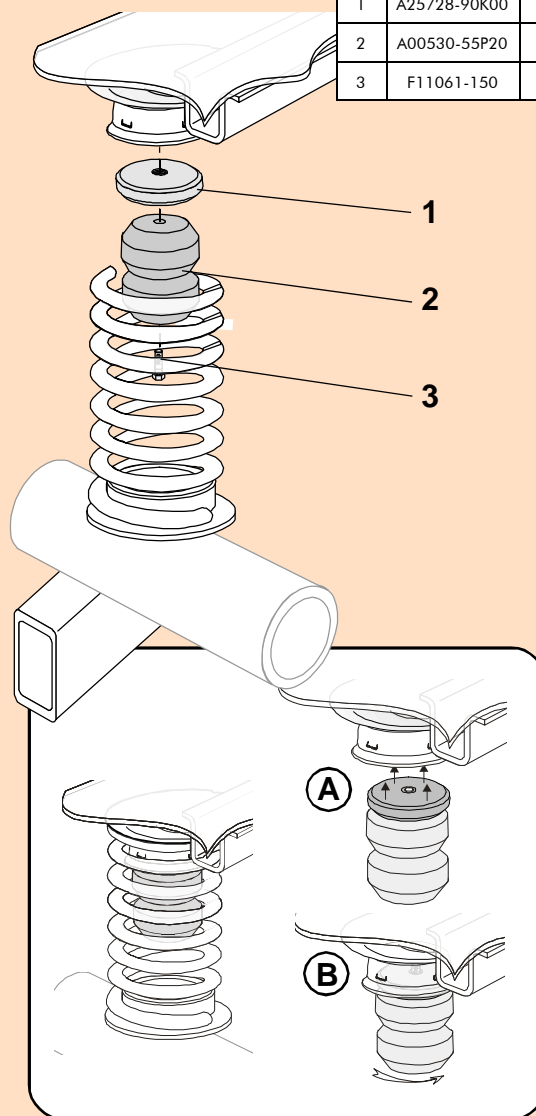

JRL4

TIMBERN

# TIMBREN SES

## Suspension Enhancement Systems



Ride Quality Control

Typical Light Duty Installation

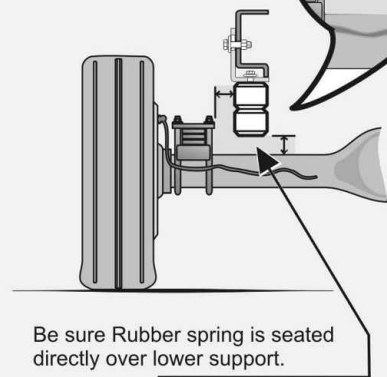

Be sure Rubber spring is seated directly over lower support.

Typical Medium & Heavy Duty Installation

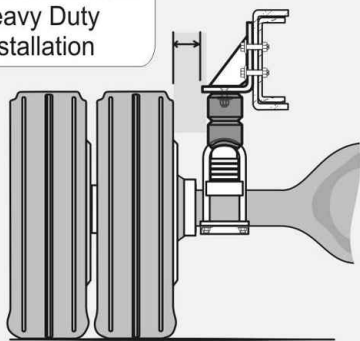

Timbren Industries Inc. ©

### Clearance Instructions

#### For Light Duty Pickups & Vans

Rear SES kits should have approximately 1" gap between rubber spring and axle for 1/2 and 3/4 tons, and for one ton the gap should be about 1/2" when the vehicle is completely unloaded. A cap or fifth wheel plate will reduce or eliminate this gap.

Front SES kits are usually in contact with the front suspension at all times.

#### For Medium Duty & Heavy Duty Trucks, Trailers, Motor Homes, and more

Medium & Heavy Duty vehicles often have pre-load as outlined in the instruction sheet. *(For specific Medium Duty applications with a constant load on the suspension like Rvs, Utility Vans or Cube Vans, the Timbren SES kits are pre-loaded.)*

**Check clearances when vehicle is empty...**

### Consider Your Needs..!

Knowing the use of the vehicle will help you to select the right SES kit. For example a one ton truck can be configured as a pick-up, service vehicle or tow truck. Standard capacity or severe service applications are available for many applications.

Knowing that the suspension has been modified or is old and sagging should indicate the need to adjust the ride height to obtain the correct clearance.

This can be done by altering the SES kit (changing rubber spring or bracket) or re-arching the leaf springs to renew the optimum OEM ride height.

## Lifetime Warranty

TIMBREN SES kits are warranted against defects in material and workmanship, under normal use and service, for the life of the vehicle on which the kit was originally installed. The warranty is not transferable and proof of purchase is required. The warranty is limited to the replacement of the failed part. TIMBREN will not be responsible for any labour or freight charges involved in the replacement of any product. TIMBREN shall be entitled to make its own inspection to determine the validity of the warranty claim. TIMBREN shall not be liable nor warrant the product in the event of alteration, misuse, overload, negligence or damage caused by others.

If ride or performance of our product is unsatisfactory in any way, please call:

**TIMBREN INDUSTRIES INC.**

**1-800-263-3113**



[www.timbren.com](http://www.timbren.com)

email: [sales@timbren.com](mailto:sales@timbren.com)